

Amphenol®

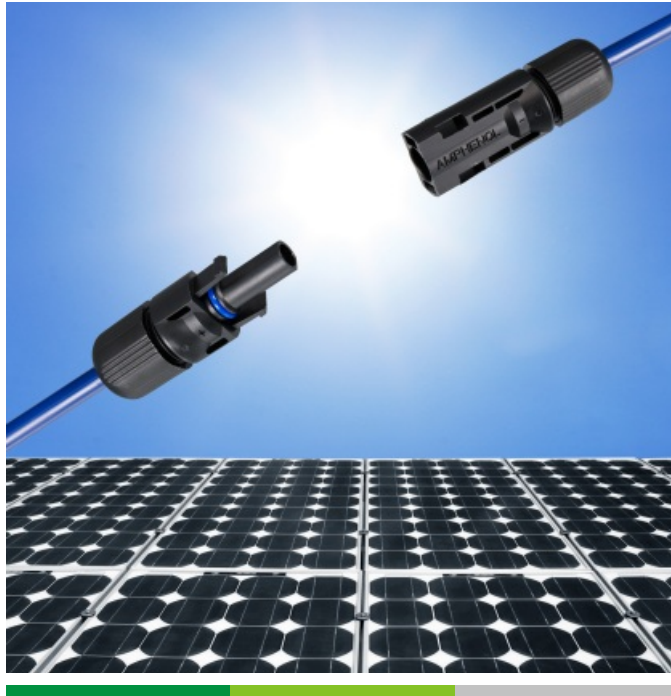

HELIOS H4

Industrial Operations (AIO) offers products and solutions for all segments of the solar electric system. AIO understands the need for efficient (low loss) power transfer, highly reliable, and cost effective solutions that are required to be competitive in this industry. We can provide panel manufacturers, installers, and OEM's with connectivity products for both thin film and crystalline silicon technologies. Amphenol® has a broad range of technologies to help minimize the cost of inverters and power conditioners. Amphenol® Industrial can help you power the planet with the sun. The Helios H4 connector is just one of the solar connector solutions Amphenol® Industrial has to offer.

H4 Features:

- Fully intermateable with industry standard
- Meets all new NEC 2008 requirements
- Quick and easy secure snap lock mating
- Simple unlocking tool meets NEC requirements
- Long-term UV and Ozone resistance
- Highest current rating in industry
- RoHS compliant
- Complete Cable Assemblies available
- Low contact resistance means low power loss
- Ready for field assembly
- No assembly required, no small parts to lose



Solar Connector

Technical Specifications

Technical Data

Rated current	36A(2.5mm ² ,AWG14),45A(4.0mm ² ,AWG12),52A(6.0mm ² ,AWG10)
Rated voltage	1000V (IEC)
	600V (UL)
Typical contact resistance	0.25mΩ
Contact material	copper, tin plated
Insulation material	PBT
Locking system	snap-lock, special unlock tool required to un-mate
Degree of protection, mated	IP68
Insulation materials flammability class	UL94-V0
Cable strain relief according to	DIN V VDE 0126-3
Ambient temperature range	-40°C --- +90°C (IEC)
Contact system	Amphenol RADSOK [®] , machined/cold formed contact with lamellar contact grid, barrel crimp.



Ordering information

Part No.	Description	Wire range
PV-090506-000	H4 Cable Connector, Mated Pair	6.0mm ² /AWG10
PV-090507-000	H4 Cable Connector, Mated Pair	2.5mm ² /AWG14
PV-090508-000	H4 Cable Connector, Mated Pair	4.0mm ² /AWG12

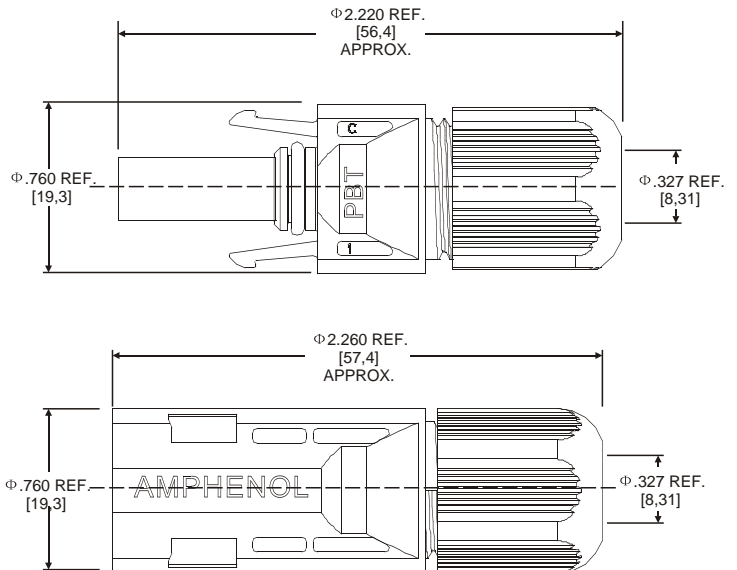
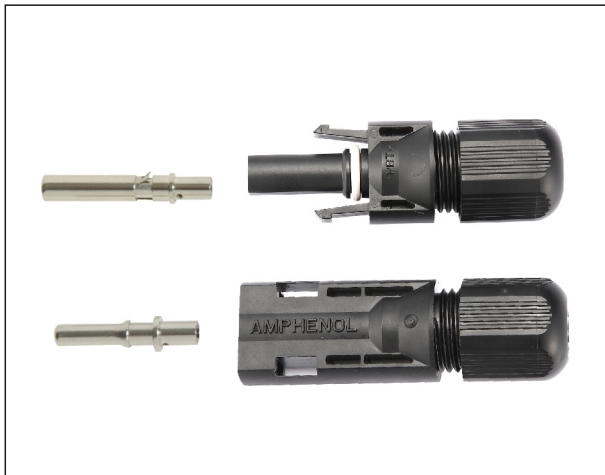

UL approval in process

Notice: Specifications are subject to change without notice. Contact your nearest Amphenol Corporation Sales Office for the latest specifications. All statements, information and data given herein are believed to be accurate and reliable but are presented without guarantee, warranty, or responsibility of any kind, expressed or implied. Statements of suggestions concerning possible use of our products are made without representation or warranty that any such use is free of patent infringement and are not recommendations to infringe any patent. The user should assume that all safety measures are indicated or that other measures may not be required. Specifications are typical and may not apply to all connectors.

For further information on your individual application requirements, contact: Amphenol Corporation

North America:

Amphenol Industrial Operations
40-60 Delaware Avenue,
Sidney, NY 13838-1395
Tel: 1-520-285-5114 1-888-364-9011
Fax: 1-520-397-7169
E-mail: energy@amphenol-ai.com

Europe:

Amphenol Industrial Operations
Europe Via Barbaiana 5
1-20020 Lainate (MI) Italy
Tel: +39 02 93254.204
Fax: +39 02 93254.444
Email: info@amphenol-ai.com

Middle East:

Amphenol Middle East Enterprises FZE
Office C-37 PO Box 21107
Ajman Free Zone, UAE
Tel: +9716-7422494
Fax: +9716-7422941
Email: ameefze@eim.ae

Asia:

Amphenol Technology Shenzhen Ltd
Block 5 Fuan 2nd Industrial Park Dayang Rd,
Fuyong Baoan Baoan, Shenzhen, China 518103
Tel: +86 755 2881 8389
Fax: +86 755 2991 8310
Email: enquiry@amphenol-industrial.com